

Specifications

Models	GR™-20J		GR™-26J	
Measurements	Metric	US	Metric	US
Working height maximum*	7.70 m	24 ft 8 in	9.85 m	32 ft 4 in
Platform height maximum	5.70 m	18 ft 8 in	7.90 m	25 ft 11 in
Horizontal reach maximum	2.75 m	9 ft	2.65 m	8 ft 8 in
Working horizontal reach maximum	3.25 m	10 ft 7 in	3.15 m	10 ft 3 in
Up-and-over clearance maximum	4.25 m	13 ft 10.7 in	6.70 m	21 ft 10.5 in
A Platform length	75 cm	2 ft 5.5 in	75 cm	2 ft 5.5 in
B Platform width	90 cm	2 ft 11 in	90 cm	2 ft 11 in
Toeboard height	15 cm	6 in	15 cm	6 in
C Height - stowed	1.99 m	6 ft 6 in	1.99 m	6 ft 6 in
D Length - stowed	2.95 m	9 ft 8 in	2.82 m	9 ft 3 in
E Width	99 cm	3 ft 3 in	99 cm	3 ft 3 in
F Wheelbase	1.20 m	3 ft 11 in	1.20 m	3 ft 11 in
G Ground clearance - centre	10 cm	4 in	10 cm	4 in

Productivity

Maximum platform occupancy (indoor/outdoor)	2/1	2/1	2/1	2/1
Lift capacity	200 kg	440 lbs	200 kg	440 lbs
Vertical jib rotation	140° (+70°/-70°)		140° (+70°/-70°)	
Turntable rotation	350° non-continuous		350° non-continuous	
Turntable tailswing	9 cm	3.74 in	9 cm	3.74 in
Drive speed - stowed	4.5 km/h	2.8 mph	4.5 km/h	2.8 mph
Drive speed - raised	0.65 km/h	0.4 mph	0.65 km/h	0.4 mph
Gradeability**	25%	25%	25%	25%
Turning radius - inside	59 cm	1 ft 11 in	59 cm	1 ft 11 in
Turning radius - outside	2.08 m	6 ft 10 in	2.08 m	6 ft 10 in
Raise / lower speed	24 s/19 s	24 s/19 s	54 s/40 s	54 s/40 s
Controls	24 V DC proportional		24 V DC proportional	
Drive	dual rear wheel		dual rear wheel	
Disc brakes	dual rear wheel		dual rear wheel	
Tyres (solid non-marking)	40.5 cm diam. 16-5-11 ¼		40.5 cm diam. 16-5-11 ¼	

Power

Power source	24 V DC (twelve 2 V batteries, 250 Ah capacity)			
Hydraulic system capacity	22 L	4.84 gal	22 L	4.84 gal

Sound & Vibration Levels

Sound pressure level (ground workstation)	<70 dBA	<70 dBA	<70 dBA	<70 dBA
Sound pressure level (platform workstation)	<70 dBA	<70 dBA	<70 dBA	<70 dBA
Vibration	<2.5 m/s ²	<8 ft 2 in/s ²	<2.5 m/s ²	<8 ft 2 in/s ²

Weight***

	2,250 kg	4,960 lbs	2,650 kg	5,842 lbs
--	----------	-----------	----------	-----------

Standards Compliance

EU Directives: 2006/42/EC - Machinery (harmonized standard EN280:2001+A2:2009); 2004/108/EC (EMC); 2006/95/EC (LVD)

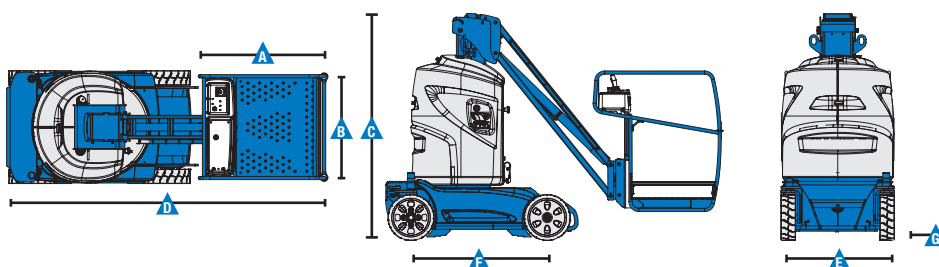

Range Of Motion GR-20 J

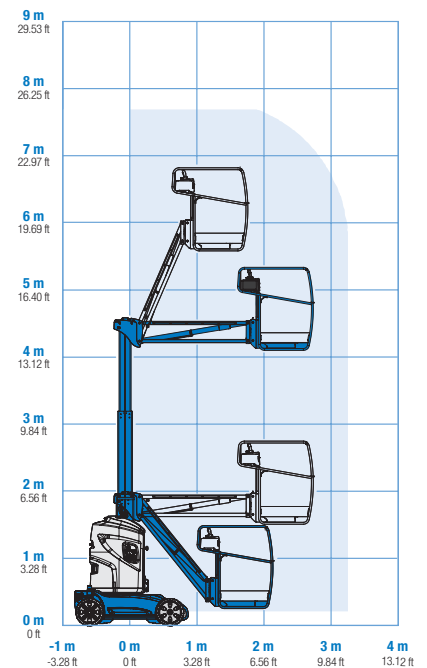

Range Of Motion GR26 J

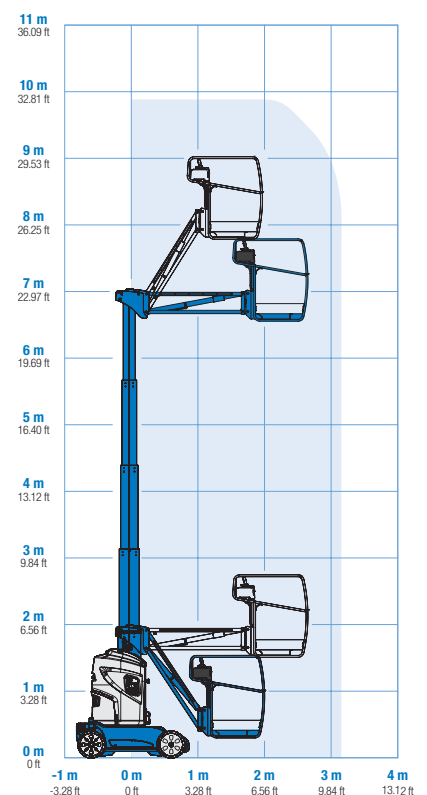

* The metric equivalent of working height adds 2 m to platform height. U.S. adds 6 ft to platform height.

** Gradeability applies to driving on slopes. See operator's manual for details regarding slope ratings.

*** Weight will vary depending on options and/or country standards.

Features

Standard Features	Easily Configured To Meet Your Needs	Options & Accessories
-------------------	--------------------------------------	-----------------------

Measurements

GR™-20J

- 7.70 m (24 ft 8 in) working height
- 3.25 m (10 ft 7 in) working horizontal reach
- 4.25 m (13 ft 10.7 in) up-and-over clearance
- 200 kg (440 lbs) lift capacity
- 1.61 m (5 ft 3 in) jib boom with 140° working range

GR™-26J

- 9.85 m (32 ft 4 in) working height
- 3.15 m (10 ft 3 in) working horizontal reach
- 6.70 m (21 ft 10.5 in) up-and-over clearance
- 200 kg (440 lbs) lift capacity
- 1.45 m (4 ft 10 in) jib boom with 140° working range

Productivity

- Hydraulic turntable rotation
- Fully proportional lift and drive system
- Drivable at full height
- Low 15 cm (6 in) platform entry height
- Maintenance free rigid steel hydraulic mast
- 99 cm (3 ft 3 in) compact width
- Low unit height of 1.99 m (6 ft 6 in)
- Low weight
- Onboard diagnostic system
- Direct electric rear wheel drive with electric parking brake
- Front wheel steering
- Brake release switch
- Reinforced ABS chassis covers
- Tie down attachments points
- Overhead crane attachment points
- Drive enable system
- Horn
- Hour meter
- Tilt level sensor with audible alarm
- Platform overload sensing
- Manual platform lowering valve
- Emergency stop at both platform and ground controls
- Certified load sensor

Power

- Automatic 25 amp battery charger

Platform

- Standard steel platform 0.90 m x 0.75 m (2 ft 11 in x 2 ft 5.5 in) with sliding midrail

Power

- 24 V DC (twelve 2V, 250 Ah traction batteries) with automatic 30 Amp 24 V battery onboard charger and battery charge indicator
- Maintenance-free batteries⁽¹⁾

Tyres

- Non-marking solid

Productivity

- Airline to platform
- Power to platform (incl. plug, socket and ground fault interrupt leakage on request)
- Biodegradable hydraulic oil⁽¹⁾
- Flashing beacon
- AC power to platform
- Platform work lights



⁽¹⁾ Factory-fit option only

United Kingdom

The Maltings, Wharf Road, Grantham NG31 6BH, T: +44 800 988 3739 (toll free), Fax +44 (0)1476 584334, Email AWP-InfoEurope@terex.com
Visit www.genielift.co.uk/locations to view our global locations list.

Worldwide Manufacturing And Distribution

Australia · Brazil · Caribbean · Central America · China · France · Germany · Italy · Japan · Korea · Mexico · Russia · Southeast Asia · Spain · Sweden · United Arab Emirates · United Kingdom · United States

Effective Date: December, 2012. Product specifications and prices are subject to change without notice or obligation. The photographs and/or drawings in this document are for illustrative purposes only. Refer to the appropriate Operator's Manual for instructions on the proper use of this equipment. Failure to follow the appropriate Operator's Manual when using our equipment or to otherwise act irresponsibly may result in serious injury or death. The only warranty applicable to our equipment is the standard written warranty applicable to the particular product and sale and we make no other warranty, express or implied. Products and services listed may be trademarks, service marks or trade names of Terex Corporation and/or their subsidiaries in the USA and many other countries. Genie is a registered trademark of Terex South Dakota, Inc. © 2012 Terex Corporation.

